

VICTRONIX	Add:	Room 1405A, Building 1B, Hua qiang Idea Park, Guang Ming District, ShenZhen,China	
	Tel:	+86-755-33265935	Fax: +86-755-33265935

SPECIFICATION

VXT350BQS-01

Preliminary Specification

Final Specification

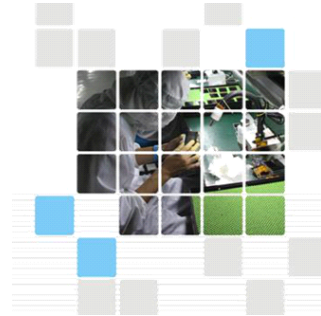

VICTRONIX COMPANY LIMITED

CUSTOMER:

Made By:

Checked By:

Approved By:

Quality:

Date:

Note:

Approved By:

Date:

Note:

Records of Revision

DATE	REF.PAGE PARAGRAPH DRAWING No.	REVISED No.	SUMMARY	REMARK
2019-10-31		V01	First Issue	

Contents

1. General Specification.....	4
2. Mechanical Drawing.....	5
3. Block Diagram.....	7
4. Interface Pin Function.....	8
5. Absolute Maximum Ratings.....	10
6. Electrical Characteristics.....	11
7. Optical Characteristics.....	13
8. Timing Characteristics.....	16
9. Standard Specification for Reliability.....	19
10. Specification of Quality Assurance.....	21
11. Handling Precaution.....	30
12. Packing Method.....	31

1. General Specification

Item	Contents	Unit
LCD type	TFT/NORMALLY BLACK	
Module size (W*H*T)	76.9*63.9*3.2	mm
Active size (W*H)	70.08*52.56	mm
Pixel pitch (W*H)	0.219*0.219	mm
Number of dots	320*RGB*240	
Driver IC	ST7272A	
Interface type	24Bit- RGB+SPI	
Top polarizer type	Glare	
Recommend viewing direction	All	O'clock
Gary scale inversion direction	-	O'clock
Backlight type	6-Dies white LED	
Touch panel type	WITHOUT	

PIN DESCRIPTION	
1	LEDK 29 R1
2	LEDK 30 R2
3	LEDA 31 R3
4	LEDA 32 R4
5	NC 33 R5
6	NC 34 R6
7	NC 35 R7
8	RESET 36 HSYNC
9	SPENA 37 VSYNC
10	SPCLK 38 DCLK
11	SPDAT 39 NC
12	B0 40 NC
13	B1 41 VDD
14	B2 42 VDD
15	B3 43 NC
16	B4 44 NC
17	B5 45 NC
18	B6 46 NC
19	B7 47 NC
20	G0 48 NC
21	G1 49 NC
22	G2 50 NC
23	G3 51 NC
24	G4 52 DEN
25	G5 53 GND
26	G6 54 GND
27	G7
28	R0

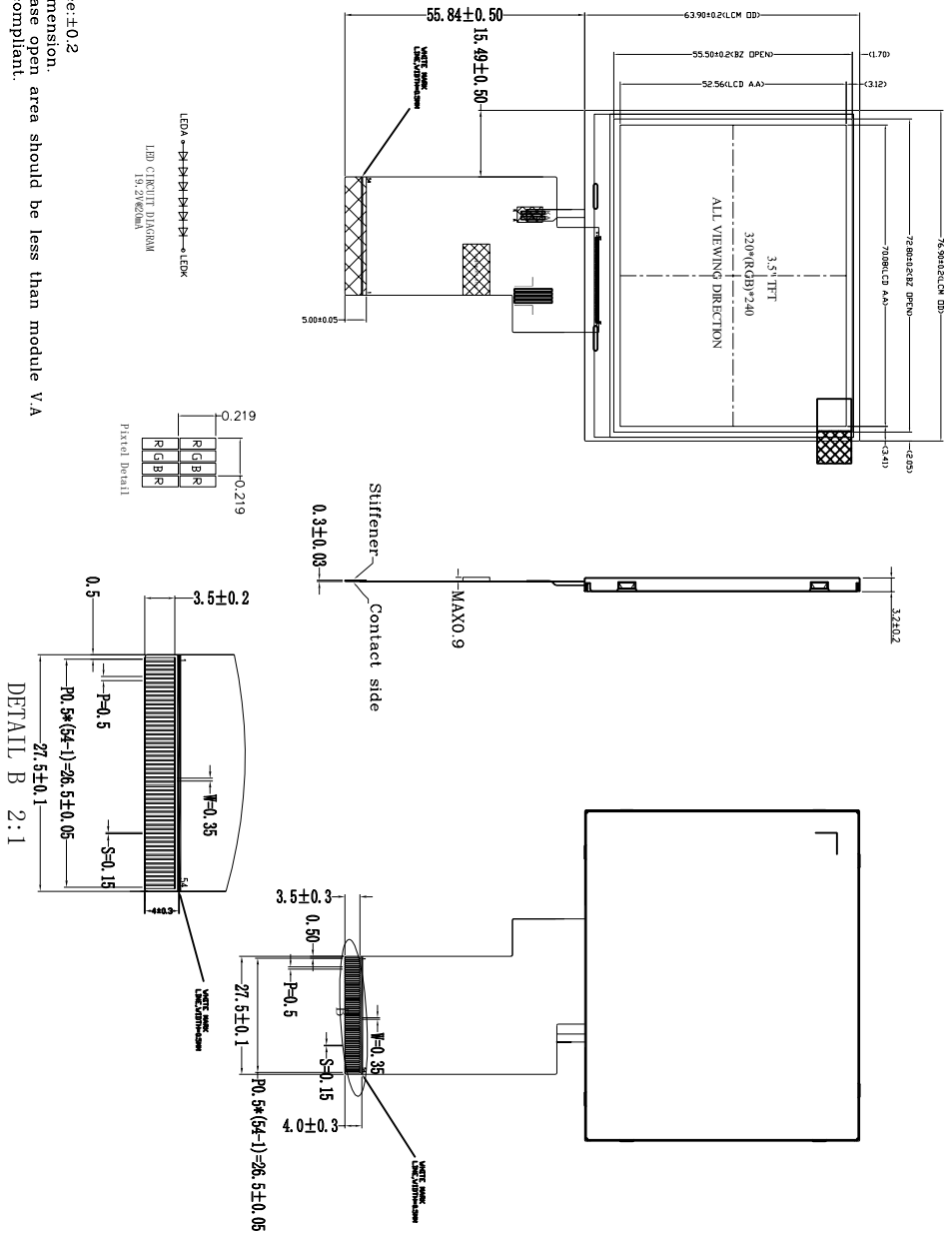

- NOTES:
1. General Tolerance:±0.2
 2. () reference dimension.
 3. Recommended case open area should be less than module V/A
 4. RoHS must be compliant.

DRAWN		TITLE	
ME.CHECKED		MODULE SPEC.	
BE.CHECKED		DRAWING NO.	
APPROVED		VXT350BQS-01	
		UNIT	mm
		SCALE	SHEET 1 OF 1
		3rd Angle	
First issue		Victronix Tecenstar INT'L Co., LTD	
AMENDMENT			
VER.	SYMBOL	SIGN	DATE
V00			2019.07.11A
		CUSTOMER'S APPROVAL	

Display Type	TFT,NORMALLY BLACK
Optimum Viewing Direction	TRANSMISSIVE, POSITIVE
Top Polarizer Type	Glare
LCD Driver IC	S17272A
Operating Voltage	VDD=3.3V
Operation Temperature	-20°C TO 70°C
Storage Temperature	-30°C TO 80°C
Interface	24BIT - RGB+SPl
Backlight Driver Voltage	6-LED Wh
BL Surface luminance	6cd/m2(tp)
White X/Y	BD

3. Block Diagram

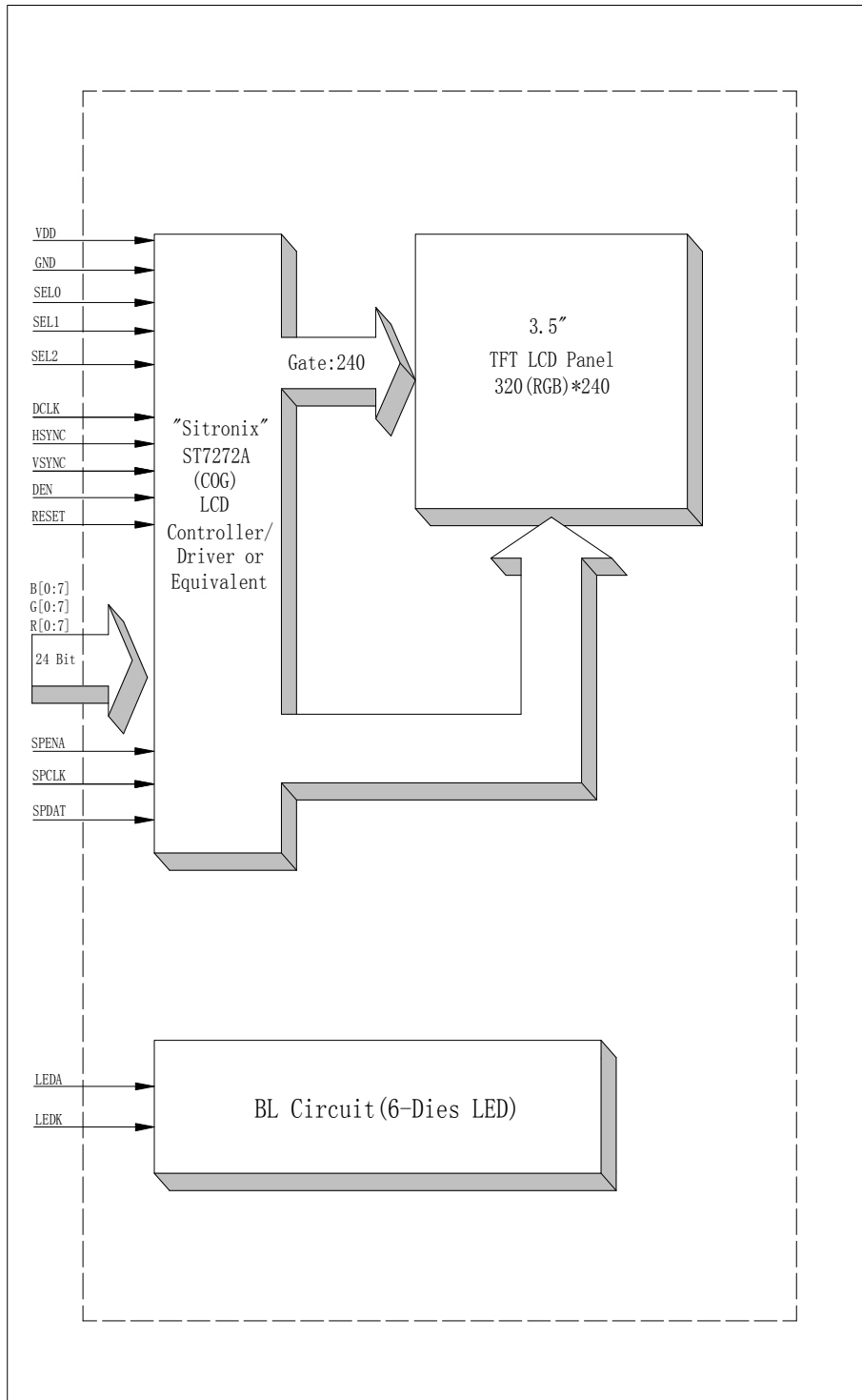

4. Interface Pin Function

Pin No.	Symbol	Description
1	LEDK	Cathode of LED backlight.
2	LEDK	Cathode of LED backlight.
3	LEDA	Anode of LED backlight.
4	LEDA	Anode of LED backlight.
5	NC	No connection
6	NC	No connection
7	NC	No connection
8	RESET	Global reset pin.
9	SPENA	Chip select of serial interface
10	SPCLK	Clock pin of serial interface
11	SPDAT	Data input pin of serial interface
12	B0	Blue data(LSB)
13	B1	Blue data
14	B2	Blue data
15	B3	Blue data
16	B4	Blue data
17	B5	Blue data
18	B6	Blue data
19	B7	Blue data(MSB)
20	G0	Green data(LSB)
21	G1	Green data
22	G2	Green data
23	G3	Green data
24	G4	Green data
25	G5	Green data
26	G6	Green data
27	G7	Green data(MSB)
28	R0	Red data(LSB)
29	R1	Red data
30	R2	Red data
31	R3	Red data
32	R4	Red data
33	R5	Red data
34	R6	Red data
35	R7	Red data(MSB)
36	HSYNC	Horizontal sync signal, default is negative polarity.
37	VSYNC	Vertical sync signal, default is negative polarity.
38	DCLK	Pixel clock input pin
39	NC	No connection
40	NC	No connection
41	VDD	Power supply
42	VDD	Power supply

43	NC	No connection
44	NC	No connection
45	NC	No connection
46	NC	No connection
47	NC	No connection
48	NC	No connection
49	NC	No connection
50	NC	No connection
51	NC	No connection
52	DEN	Data input enable. Display access is enabled when DE is "H".
53	GND	Power ground.
54	GND	Power ground.

5. Absolute Maximum Ratings

Parameter	Symbol	Min	Max	Unit
Supply voltage for analog	VDD	-0.3	4.5	V
Supply voltage for logic	VDD	-0.3	4.5	V
Supply current (One LED)	I _{LED}		30	mA
Operating temperature	T _{OP}	-30	+80	°C
Storage temperature	T _{ST}	-30	+85	°C

6. Electrical Characteristics

6.1 Input Power

Item	Symbol	Min	Typ.	Max	Unit	Applicable terminal
Supply Voltage for Analog	VDD	3.0	3.3	3.6	V	
Supply Voltage for Logic	VDD	3.0	3.3	3.6	V	
Input Voltage	V _{IL}	GND	-	0.3VDD	V	
	V _{IH}	0.7 VDD	-	VDD		
Input leakage Current	I _{LKG}	-		-	μA	

6.2 Backlight Driving Conditions

Item	Symbol	Value			Unit	Remark
		Min.	Typ.	Max.		
Voltage for LED Backlight	V _F	16.8	18.6	20.4	V	I _L =20mA
Current for LED Backlight	I _L		20		mA	
Power Consumption	P		0.372		W	
LED Life Time		30,000	50,000		Hr	Note

Note: Brightness to be decreased to 50% of the initial value at ambient temperature TA=25°C

7. Optical Characteristics

ITEM	SYMBOL	CONDITIONS	SPECIFICATIONS			UNIT	NOTE
			MIN	TYP.	MAX		
Luminance	L	$I_L = 20\text{mA}$	250	320	450	Cd/m^2	
Contrast Ratio	CR	$\theta = 0^\circ$	640	800			
Response Time	T_{ON}	25°C		30	40	ms	
	T_{OFF}						
CIE Color Coordinate	Red	X_R	Viewing normal angle	0.5913	0.6313	0.6713	
		Y_R		0.3096	0.3496	0.3896	
	Green	X_G		0.3073	0.3473	0.3873	
		Y_G		0.5444	0.5844	0.6244	
	Blue	X_B		0.1019	0.1419	0.1819	
		Y_B		0.0463	0.0863	0.1263	
	White	X_W		0.2378	0.2778	0.3178	
		Y_W		0.2664	0.3064	0.3464	
Viewing Angle	Hor.	θ_{x+}	$\text{CR} \geq 10$	70	80	Degree	
		θ_{x-}		70	80		
	Ver.	θ_{y+}		70	80		
		θ_{y-}		70	80		
Uniformity	Un		80			%	

Note 1: Definition of Viewing Angle θ_x and θ_y :

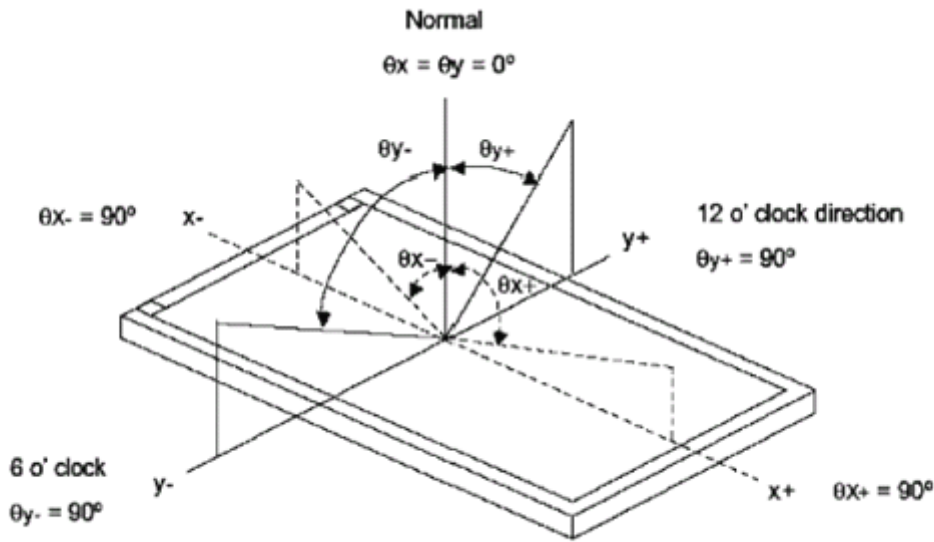

Note 2: Definition of contrast ratio CR:

$$CR = \frac{\text{Luminance of white state}}{\text{Luminance of black state}}$$

Note 3: Definition of Response Time (T_r, T_f)

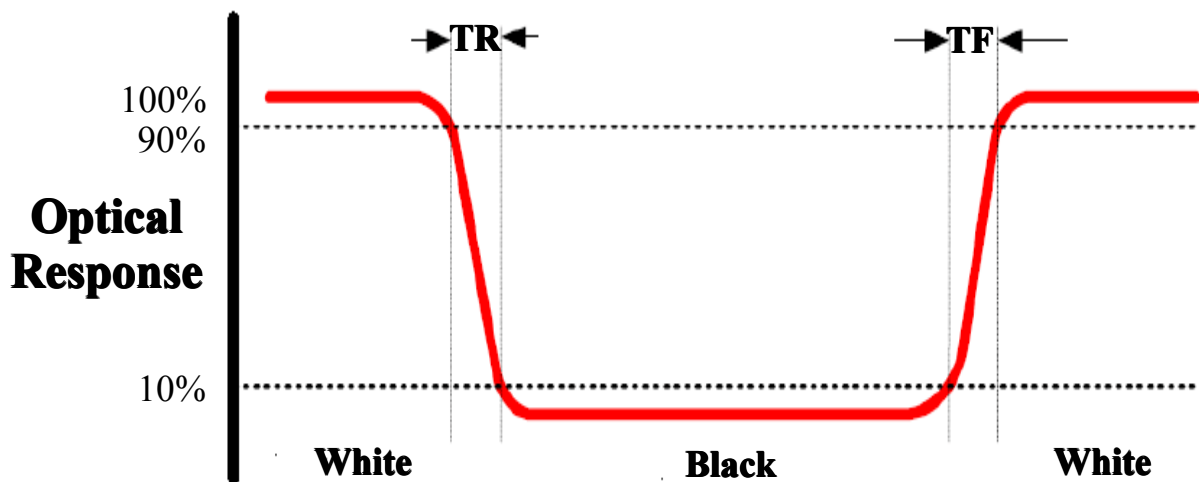

Note 4: Definition of Luminance

①The Brightness Test Equipment Setup

Field=2°(As measuring “black” image, field=2°is the best testing condition)

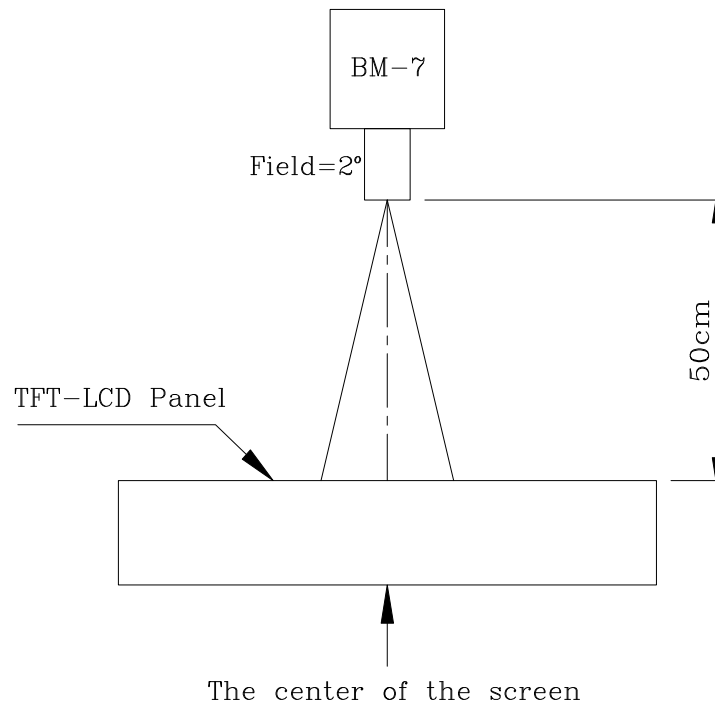

②The Brightness Test Point Setup

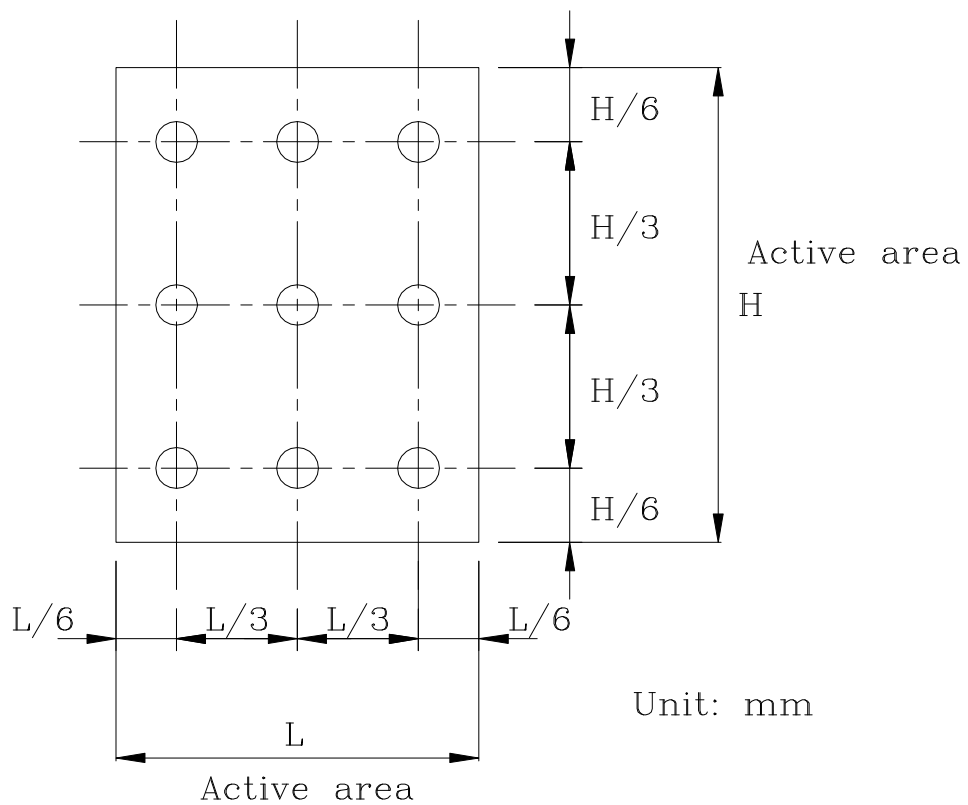

8. Timing Characteristics

8.1 System Bus Timing for 3-Wire SPI Interface

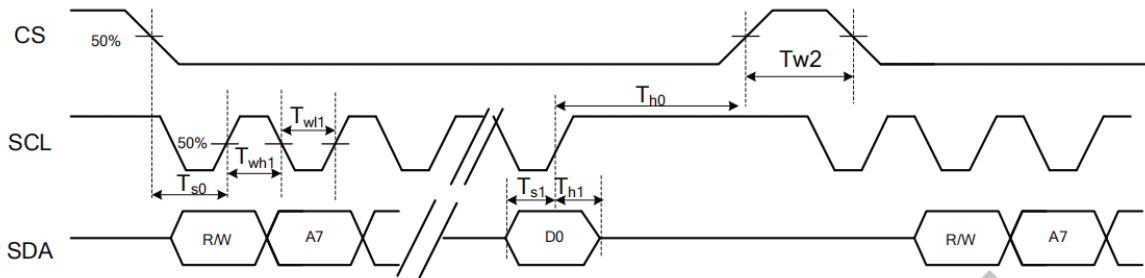

Item	Symbol	Min.	Typ.	Max.	Unit	Conditions
CS Input Setup Time	Ts0	50	-	-	ns	
Serial Data Input Setup Time	Ts1	50	-	-	ns	
CS Input Hold Time	Th0	50	-	-	ns	
Serial Data Input Hold Time	Th1	50	-	-	ns	
SCL Write Pulse High Width	Twh1	50	-	-	ns	
SCL Write Pulse Low Width	Twl1	50	-	-	ns	
SCL Read Pulse High Width	Trh1	300			ns	
SCL Read Pulse Low Width	Trl1	300			ns	
CS Pulse High Width	Tw2	400	-	-	ns	

8.2 System Bus Timing for RGB Interface

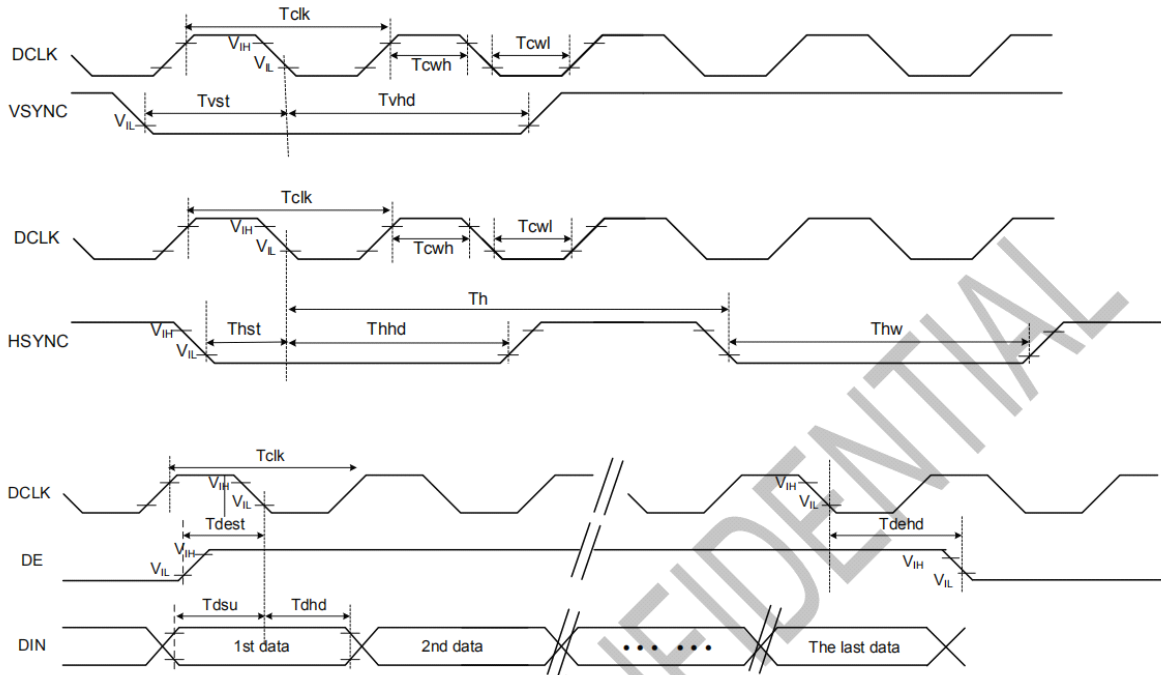

Item	Symbol	Min.	Typ.	Max.	Unit	Conditions
CLK Pulse Duty	Tclk	40	50	60	%	
HSYNC Width	Thw	2	-	-	DCLK	
HSYNC Period	Th	55	60	65	us	
VSYNC Setup Time	Tvst	12	-	-	ns	
VSYNC Hold Time	Tvhd	12	-	-	ns	
HSYNC Setup Time	Thst	12	-	-	ns	
HSYNC Hold Time	Thhd	12	-	-	ns	
Data Setup Time	Tdsu	12	-	-	ns	
Data Hold Time	Tdhd	12	-	-	ns	
DE Setup Time	Tdest	12	-	-	ns	
DE Hold Time	Tdehd	12	-	-	ns	

Parallel 24-bit RGB Input Timing (PVDD=VDD=VDDI= 3.3V, AGND= 0V, TA=25°C)

Parallel 24-bit RGB Input Timing Table							
Item	Symbol	Min.	Typ.	Max.	Unit	Remark	
DCLK Frequency	Fclk	5	6	8	MHz		
DCLK Period	Tclk	125	167	200	ns		
HSYNC	Period Time	Th	325	371	438	DCLK	
	Display Period	Thdisp		320		DCLK	
	Back Porch	Thbp	3	43	43	DCLK	By H_BLANKING setting
	Front Porch	Thfp	2	8	75	DCLK	
	Pulse Width	Thw	2	4	43	DCLK	
VSYNC	Period Time	Tv	244	260	289	HSYNC	
	Display Period	Tvdisp		240		HSYNC	
	Back Porch	Tvbp	2	12	12	HSYNC	By V_BLANKING setting
	Front Porch	Tvfp	2	8	37	HSYNC	
	Pulse Width	Tvw	2	4	12	HSYNC	

Note: It is necessary to keep Tvbp =12 and Thbp =43 in sync mode. DE mode is unnecessary to keep it.

9. Standard Specification for Reliability

9.1 Standard Specification for Reliability of LCD Module

No	Test Item	Condition	Remarks
1	High Temperature Operation	Ts = +70°C, 240 hours	IEC60068-21:2007 GB2423.2-2008
2	Low Temperature Operation	Ta = -20°C, 240 hours	IEC60068-2-1:2007 GB/2423.1-2008
3	High Temperature Storage	Ta = +80°C, 240 hours	IEC60068-21:2007 GB/2423.2-2008
4	Low Temperature Storage	Ta = -30°C, 240 hours	IEC60068-21:2007 GB/2423.1-2008
5	Storage at High Temperature and Humidity	Ta = +60°C, 90% RH max,240hours	IEC60068-2-78 :2001 GB/T2423.3—2006
6	Thermal Shock (non-operation)	-30°C 30 min~+80°C 30 min, Change time:5min, 20 Cycle	Start with cold temperature, End with high temperature, IEC60068-214:1984, GB/2423.22-2002
7	ESD	C=150pF,R=330Ω,5point/panel Air:±8Kv,5times; Contact:±4Kv,5times (Environment:15°C~35°C, 30%~60%.86Kpa~106Kpa)	IEC61000-42:2001 GB/T17626.2-2006
8	Vibration Test	Frequency range:10~55Hz Stroke:1.5mm Sweep:10Hz~55Hz~10Hz 2 hours for each direction of X.Y.Z (6 hours for total)	IEC60068-2-6:1982 GB/T2423.101995
9	Mechanical Shock (Non Op)	Half Sine Wave60G 6ms, ±X,±Y,±Z 3times for each direction	IEC60068-2-27:1987 GB/T2423.5—1995
10	Package Drop Test	Height:80cm, 1corner,3 edges,6 surfaces	IEC60068-2-32:1990 GB/T2423.8—1995

Note1: Ts is the temperature of panel's surface.

Note2: Ta is the ambient temperature of sample.

9.2 Testing Conditions and Inspection Criteria

For the final test, the testing sample must be stored at room temperature for 24 hours. After the tests listed in Table 9.2, standard specifications for reliability will be executed in order to ensure stability.

No.	Item	Test Model	In section Criteria
01	Current Consumption	Refer To Specification	The current consumption should conform to the product specification.
02	Contrast	Refer To Specification	After the tests have been executed, the contrast must be larger than half of its initial value prior to the tests.
03	Appearance	Visual inspection	Defect free.

9.3 MTBF

MTBF	Functions, performance, appearance, etc. shall be free from remarkable deterioration within 50,000 hours under ordinary operating and storage conditions room temperature ($25\pm 5^{\circ}\text{C}$), normal humidity ($50\pm 10\%$ RH), and in area not exposed to direct sun light.
------	---

10. Specification of Quality Assurance

This standard of Quality Assurance confirms to the quality of LCD module products supplied by Victronix.

10.1 Quality Test

Before delivering, the supplier should conduct the following tests to confirm the quality of products.

- Electrical-Optical Characteristics: According to the individual specification to test the product.
- Appearance Characteristics: According to the individual specification to test the product.
- Reliability Characteristics: According to the definition of reliability on the specification for testing products.

10.2 Delivery Test

Before delivering, the supplier should conduct the delivery test.

- Test method: According to MIL-STD105E.General Inspection Level II take a single Time.
- The defects classify of AQL as following:
Major defect: AQL = 0.65
Minor defect: AQL = 1.5
Total defects: AQL = 1.5

10.3 Non-conforming Analysis & Deal With Manners

10.3.1 Non-conforming Analysis

- Purchaser should provide the data detail of non-conforming sample and the non-conforming.
- After receiving the data detail from purchaser, the analysis of non-conforming should be finished within two weeks.
- If the analysis can't be finished on time, supplier must notice purchaser 3 days in advance.

10.3.2 Disposition of non-conforming

- If any product defect be found during assembling, supplier must change the good for every defect after confirmation.
- Both supplier and customer should analyze the reason and discuss the disposition of non-conforming when the reason of nonconforming is not sure.

10.4 Agreement items

Both parties should negotiate together when the following problems happen.

- There is any problem of standard of quality assurance, and both sides should agree that it must be modified.
- There is any argument item which does not record in the standard of quality assurance.
- Any other special problem.

10.5 Standard of The Product Appearance Test

10.5.1 Manner of appearance test

- The test must be under 20W × 2 or 40W fluorescent light, and the distance of view must be at 30±5cm.
- When test the model of transmissive product must add the reflective plate.
- The test direction is base on around 10° of vertical line.
- Temperature: 25±5°C Humidity: 60±10%RH

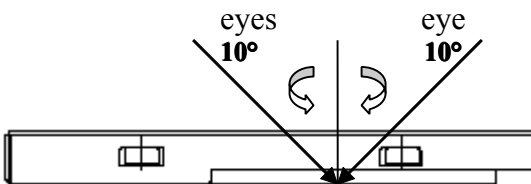

- Definition of area:

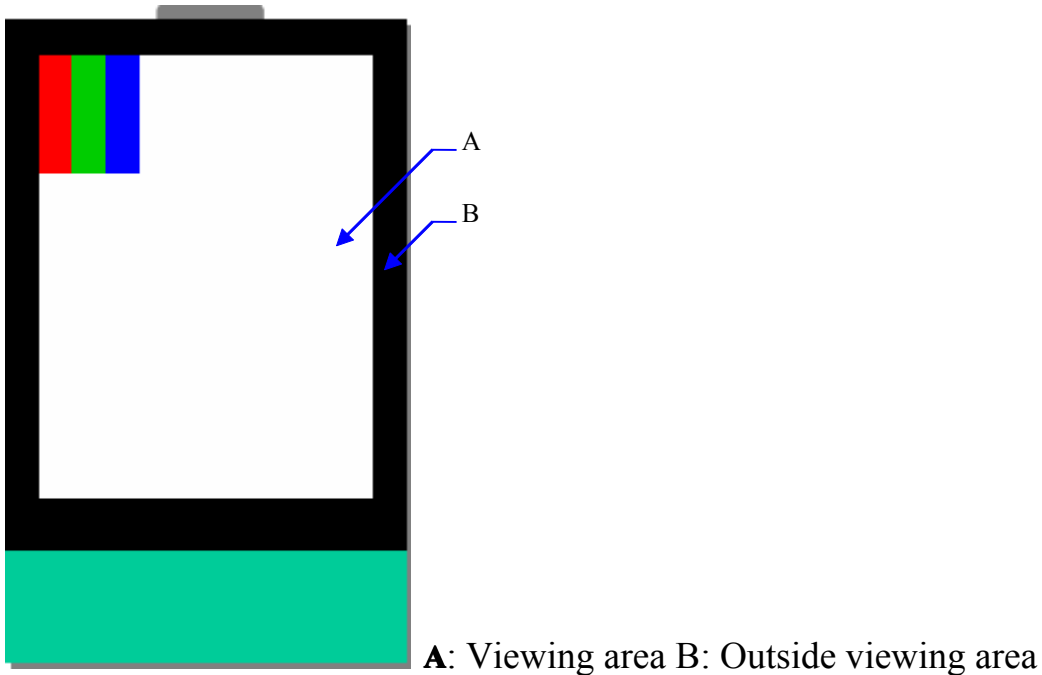

10.5.2 Basic principle

- When the standard can not be described, AQL will be applied.
- The sample of the lowest acceptable quality level must be negotiated by both supplier and customer when any dispute happened.
- New item must be added on time when it is necessary.

10.6 Inspection Specification

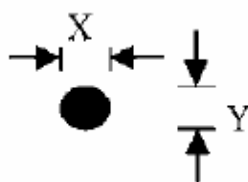
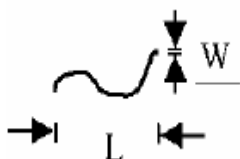
NO.	Item	Criterion	AQL												
01	Electrical Testing	1.1 Missing vertical, horizontal segment, segment contrast defect. 1.2 Missing character, dot or icon. 1.3 Display malfunction. 1.4 No function or no display. 1.5 Current consumption exceeds product specifications. 1.6 LCD viewing angle defect. 1.7 Mixed product types. 1.8 Flicker	0.65												
02	Black or White spots or Bright spots or Color spots on LCD (Display only)	2.1 White and black or color spots on display $\leq 0.25\text{mm}$, no more than Five spots. 2.2 Densely spaced: No more than three spots within 3mm.	1.5												
03	LCD and Touch Panel black spots, white spots, contamination (non – display)	3.1 Round type: As following drawing $\Phi = (X+Y) / 2$  <table border="1" data-bbox="821 1093 1353 1339"> <thead> <tr> <th>Size(mm)</th> <th>Acceptable Q'ty</th> </tr> </thead> <tbody> <tr> <td>$\Phi \leq 0.10$</td> <td>Accept no dense</td> </tr> <tr> <td>$0.10 < \Phi \leq 0.20$</td> <td>2</td> </tr> <tr> <td>$0.20 < \Phi \leq 0.25$</td> <td>2</td> </tr> <tr> <td>$0.25 < \Phi \leq 0.30$</td> <td>1</td> </tr> <tr> <td>$0.30 < \Phi$</td> <td>0</td> </tr> </tbody> </table> <p>* Densely spaced: No more than two spots within 3mm.</p>	Size(mm)	Acceptable Q'ty	$\Phi \leq 0.10$	Accept no dense	$0.10 < \Phi \leq 0.20$	2	$0.20 < \Phi \leq 0.25$	2	$0.25 < \Phi \leq 0.30$	1	$0.30 < \Phi$	0	1.5
		Size(mm)	Acceptable Q'ty												
$\Phi \leq 0.10$	Accept no dense														
$0.10 < \Phi \leq 0.20$	2														
$0.20 < \Phi \leq 0.25$	2														
$0.25 < \Phi \leq 0.30$	1														
$0.30 < \Phi$	0														
3.2 Line type: (As following drawing)  <table border="1" data-bbox="726 1496 1353 1769"> <thead> <tr> <th>Length(mm)</th> <th>Width(mm)</th> <th>Acceptable Q'ty</th> </tr> </thead> <tbody> <tr> <td>---</td> <td>$W \leq 0.02$</td> <td>Accept no dense</td> </tr> <tr> <td>$L \leq 3.0$</td> <td>$0.02 < W \leq 0.05$</td> <td rowspan="2">2</td> </tr> <tr> <td>$L \leq 2.5$</td> <td>$0.03 < W \leq 0.08$</td> </tr> <tr> <td>---</td> <td>$0.08 < W$</td> <td>Rejection</td> </tr> </tbody> </table> <p>* Densely spaced: No more than two lines within 3mm.</p>	Length(mm)	Width(mm)	Acceptable Q'ty	---	$W \leq 0.02$	Accept no dense	$L \leq 3.0$	$0.02 < W \leq 0.05$	2	$L \leq 2.5$	$0.03 < W \leq 0.08$	---	$0.08 < W$	Rejection	1.5
Length(mm)	Width(mm)	Acceptable Q'ty													
---	$W \leq 0.02$	Accept no dense													
$L \leq 3.0$	$0.02 < W \leq 0.05$	2													
$L \leq 2.5$	$0.03 < W \leq 0.08$														
---	$0.08 < W$	Rejection													

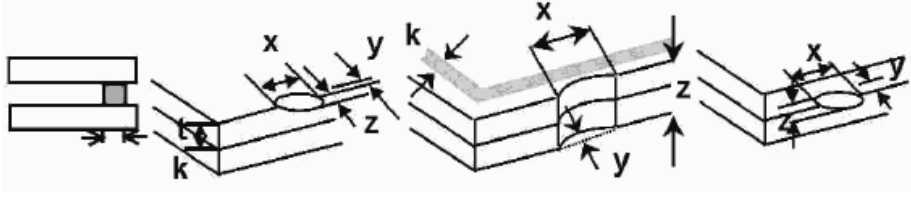
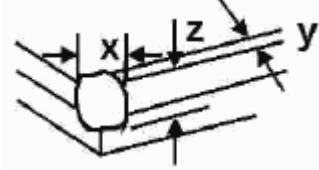
NO.	Item	Criterion		AQL	
04	Polarizer bubbles	If bubbles are visible, judge using black spot specifications, not easy to find, must check in specify direction	Size Φ (mm)	Acceptable Q'ty	1.5
			$\Phi \leq 0.20$	Accept no dense	
			$0.20 < \Phi \leq 0.50$	3	
			$0.50 < \Phi \leq 1.00$	2	
			$1.00 < \Phi$	0	
			Total Q'ty	3	
05	Scratches	Follow NO.3 -2 Line Type.			
06	Chipped glass	Symbols: x: Chip length y: Chip width z: Chip thickness k: Seal width t: Glass thickness a: LCD side length L: Electrode pad length 6.1 General glass chip: 6.1.1 Chip on panel surface and crack between panels:		1.5	
					
		z: Chip thickness	y: Chip width		x: Chip length
		$Z \leq 1/2t$	Not over viewing area		$x \leq 1/8a$
		$1/2t < z \leq 2t$	Not exceed 1/3k		$x \leq 1/8a$
		☉ Unit: mm ☉ If there are 2 or more chips, x is the total length of each chip			
6.1.2 Corner crack:		1.5			
					
z: Chip thickness	y: Chip width		x: Chip length		
$Z \leq 1/2t$	Not over viewing area		$x \leq 1/8a$		
$1/2t < z \leq 2t$	Not exceed 1/3k		$x \leq 1/8a$		
☉ Unit: mm ☉ If there are 2 or more chips, x is the total length of each chip					

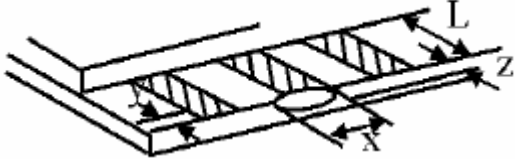
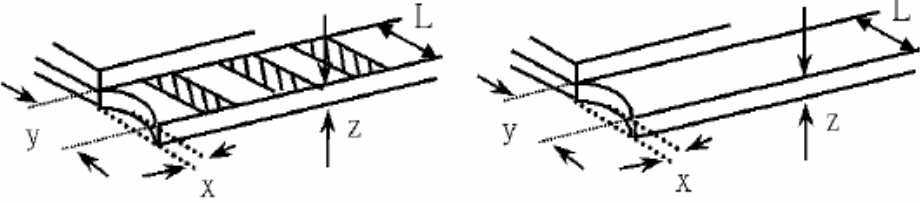
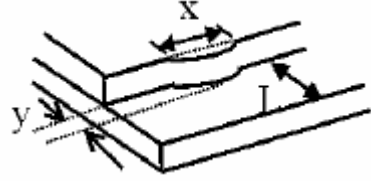
NO.	Item	Criterion	AQL																
07	Glass crack	<p>Symbols: x: Chip length y: Chip width z: Chip thickness k: Seal width t: Glass thickness a: LCD side length L: Electrode pad length</p> <p>7.2 Protrusion over terminal: 7.2.1 Chip on electrode pad:</p>  <table border="1" data-bbox="560 757 1236 902"> <tr> <td>y: Chip width</td> <td>x: Chip length</td> <td>z: Chip thickness</td> </tr> <tr> <td>$y \leq 0.5\text{mm}$</td> <td>$x \leq 1/8a$</td> <td>$0 < z \leq t$</td> </tr> </table> <p>7.2.2 Non-conductive portion:</p>  <table border="1" data-bbox="560 1272 1236 1417"> <tr> <td>y: Chip width</td> <td>x: Chip length</td> <td>z: Chip thickness</td> </tr> <tr> <td>$y \leq L$</td> <td>$x \leq 1/8a$</td> <td>$0 < z \leq t$</td> </tr> </table> <p>⊙ If there chipped area touches the ITO terminal, over 2/3 of the ITO must remain and be inspected according to electrode terminal specifications. ⊙ If the product will be heat sealed by the customer, the alignment mark must not be damaged.</p> <p>7.2.3 Substrate protuberance and internal crack</p>  <table border="1" data-bbox="890 1742 1326 1888"> <tr> <td>y: width</td> <td>x: length</td> </tr> <tr> <td>$y \leq 1/3L$</td> <td>$X \leq a$</td> </tr> </table>	y: Chip width	x: Chip length	z: Chip thickness	$y \leq 0.5\text{mm}$	$x \leq 1/8a$	$0 < z \leq t$	y: Chip width	x: Chip length	z: Chip thickness	$y \leq L$	$x \leq 1/8a$	$0 < z \leq t$	y: width	x: length	$y \leq 1/3L$	$X \leq a$	1.5
y: Chip width	x: Chip length	z: Chip thickness																	
$y \leq 0.5\text{mm}$	$x \leq 1/8a$	$0 < z \leq t$																	
y: Chip width	x: Chip length	z: Chip thickness																	
$y \leq L$	$x \leq 1/8a$	$0 < z \leq t$																	
y: width	x: length																		
$y \leq 1/3L$	$X \leq a$																		

NO.	Item	Criterion	AQL
08	Cracked glass	The LCD with extensive crack is not acceptable.	1.5
09	Backlight elements	9.1 Illumination source flickers when lit. 9.2 Spots or scratches that appear when lit must be judged. Using LCD spot, lines and contamination standards. 9.3 Backlight doesn't light or color is wrong.	1.5 1.5 0.65
10	Bezel	Bezel must comply with product specifications.	1.5
11	PCB、COB	11.1 COB seal may not have pinholes larger than 0.2mm or contamination. 11.2 COB seal surface may not have pinholes through to the IC. 11.3 The height of the COB should not exceed the height indicated in the assembly diagram. 11.4 There may not be more than 2mm of sealant outside the seal area on PCB. And there should be no more than three places. 11.5 Parts on PCB must be the same as on the production characteristic chart, There should be no wrong parts, missing parts or excess parts. 11.6 The jumper on the PCB should conform to the product characteristic chart.	1.5 1.5 1.5 1.5 0.65 0.65
12	FPC	12.1 FPC terminal damage \cong 1/2 FPC terminal width and can not affect the function , we judge accept. 12.2 FPC alignment hole damage \cong 1/2 alignment area and can not affect the function , we judge accept.	1.5 1.5
13	Soldering	13.1 No cold solder joints, missing solder connections, oxidation or icicle. 13.2 No short circuits in components on PCB or FPC.	1.5 0.65

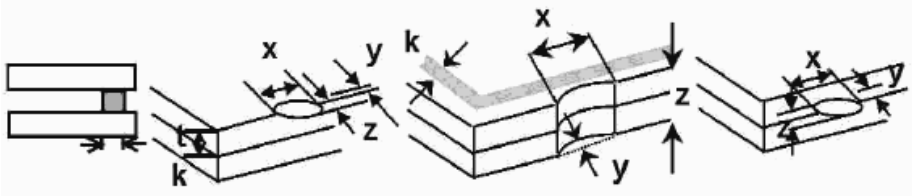
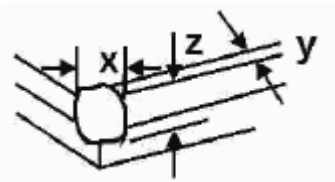
NO.	Item	Criterion	AQL												
14	Touch Panel Chipped glass	<p>Symbols: x: Chip length y: Chip width z: Chip thickness k: Seal width t: Touch Panel Total thickness a: LCD side length L: Electrode pad length</p> <p>14.1 General glass chip: 14.1.1 Chip on panel surface and crack between panels:</p>  <table border="1" data-bbox="451 752 1270 969"> <tr> <td>z: Chip thickness</td> <td>y: Chip width</td> <td>x: Chip length</td> </tr> <tr> <td>$Z \leq t$</td> <td>$\cong 1/2 k$ and not over viewing area</td> <td>$x \leq 1/8a$</td> </tr> </table> <p>⊙ Unit: mm ⊙ If there are 2 or more chips, x is the total length of each chip</p> <p>14.1.2 Corner crack:</p>  <table border="1" data-bbox="451 1346 1270 1563"> <tr> <td>z: Chip thickness</td> <td>y: Chip width</td> <td>x: Chip length</td> </tr> <tr> <td>$z \leq t$</td> <td>$\cong 1/2 k$ and not over viewing area</td> <td>$x \leq 1/8a$</td> </tr> </table> <p>⊙ Unit: mm ⊙ If there are 2 or more chips, x is the total length of each chip</p>	z: Chip thickness	y: Chip width	x: Chip length	$Z \leq t$	$\cong 1/2 k$ and not over viewing area	$x \leq 1/8a$	z: Chip thickness	y: Chip width	x: Chip length	$z \leq t$	$\cong 1/2 k$ and not over viewing area	$x \leq 1/8a$	1.5
z: Chip thickness	y: Chip width	x: Chip length													
$Z \leq t$	$\cong 1/2 k$ and not over viewing area	$x \leq 1/8a$													
z: Chip thickness	y: Chip width	x: Chip length													
$z \leq t$	$\cong 1/2 k$ and not over viewing area	$x \leq 1/8a$													

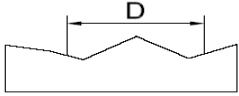
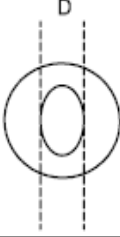
NO.	Item	Criterion	AQL										
15	Touch Panel(Fish eye、dent and bubble on film)	<table border="1" data-bbox="459 320 987 524"> <thead> <tr> <th>SIZE(mm)</th> <th>Acceptable Q'ty</th> </tr> </thead> <tbody> <tr> <td>$\Phi \leq 0.2$</td> <td>Accept no dense</td> </tr> <tr> <td>$0.2 < D \leq 0.4$</td> <td>5</td> </tr> <tr> <td>$0.4 < D \leq 0.5$</td> <td>2</td> </tr> <tr> <td>$0.5 < D$</td> <td>0</td> </tr> </tbody> </table>  	SIZE(mm)	Acceptable Q'ty	$\Phi \leq 0.2$	Accept no dense	$0.2 < D \leq 0.4$	5	$0.4 < D \leq 0.5$	2	$0.5 < D$	0	1.5
SIZE(mm)	Acceptable Q'ty												
$\Phi \leq 0.2$	Accept no dense												
$0.2 < D \leq 0.4$	5												
$0.4 < D \leq 0.5$	2												
$0.5 < D$	0												
16	Touch Panel Newton ring	Newton ring dimension $\leq 1/2$ touch panel area and not affect font and line distortion($\leq 2.5\%$) , it is acceptable.	1.5										
17	Touch Panel Linearity	Less than 2.5% is acceptable.	1.5										
18	LCD Ripple	Touch the touch panel , can not see the LCD ripple. Pen: R 1.0mm silicon rubber. Operation Force: 80g	1.5										
19	General appearance	19.1 Pin type must match type in specification sheet. 19.2 LCD pin loose or missing pins. 19.3 Product packaging must the same as specified on packaging specification sheet. 19.4 Product dimension and structure must conform to product specification sheet.	0.65 0.65 0.65 0.65										

11. Handling Precaution

11.1 Handling of LCM

- Avoid external shock.
- Don't apply excessive force on the surface.
- Liquid in LCD is hazardous substance, do not lick or swallow. When the liquid is attaching to your hand, skin, cloth, etc., wash it thoroughly and immediately.
- Don't operate it above the absolute maximum rating.
- Don't disassemble the LCM.
- The operators should wear protections whenever he/she comes into contact with the module. Never touch any of the conductive parts such as the LSI pads, the copper leads on the PCB and the interface terminals with any parts of the human body.
- The modules should be kept in antistatic bags or other containers resistant to static for storage.
- The module is coated with a film to protect the display surface, be careful when peeling off this protective film since static electricity may be generated.

11.2 Storage

- Store it in an ambient temperature of $25\pm 10^{\circ}\text{C}$, and in a relative humidity of $50\pm 10\%\text{RH}$. Don't expose to sunlight or fluorescent light.
- Store it in a clean environment, free from dust, active gas, and solvent.
- Store it in anti-static electricity container.
- Store it without any physical load.

11.3 Soldering

- Use only soldering irons with proper grounding and no leakage.
- Iron: no higher than $280\pm 10^{\circ}\text{C}$ and less than 3 sec during hand soldering.
- Rewiring: no more than 2 times.

12. Packing Method

No.	Item	Dimensions(mm)	Quantity	Remark
1	LCM Module	76.4*63.4*2.95	272PCS	
2	Pallet	344*285*85 (include 136pcs products/one tray)	2PCS	
3	carton	385*315*227 (include 272pcs products/one carton)	1PCS	